



Nominal data

Type	6318 /2 TDHHP	
Nominal voltage	VDC	48
Nominal voltage range	VDC	36 .. 72
Speed (rpm)	min ⁻¹	7000
Power consumption	W	67
Min. ambient temperature	°C	-20
Max. ambient temperature	°C	75
Air flow	m ³ /h	710
Sound power level	B	7.9
Sound pressure level	dB(A)	69

ml = Max. load · me = Max. efficiency · fa = Free air · cs = Customer specification · ce = Customer equipment
Subject to change

Technical description

General description	3-phase fan drive with very smooth operation and high efficiency Housing with grounding lug for M4 x 8 screw (Torx) Power consumption when wide open; these values may be considerably higher at the operating point.
Weight	0.910 kg
Dimensions	Ø 172 x 51 mm
Impeller material	Glass-fiber reinforced PA plastic
Housing material	Die-cast aluminum
Airflow direction	Exhaust over struts
Direction of rotation	Counterclockwise, viewed toward rotor
Storage	Ball bearing
Service life L10 at 40 °C	62500 h
Service life L10 at maximum temperature	25000 h
Cable	With leads AWG 18, 20 or AWG 22, TR 64, speed signal and control input AWG 22
Motor protection	Protection against reverse polarity and blocked rotor.

Product drawing

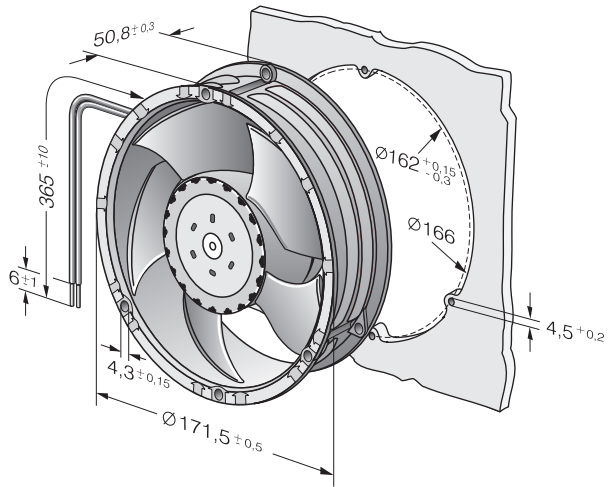

Curves

